



Yamaha-YSD 高速点胶机

General Contents

4. After-sales service (Japanese market)	9
5. Scope of construction work and service	10
6. Preconditions	11
6.1 Effective area	11
6.2 Export control by the Foreign Exchange and Foreign Trade Control Law	11
6.3 Re-export control by the U.S. Government	11
6.4 European region	11
6.5 Intellectual property right	11
6.6 Industrial machine dedicated to indoor use	11
6.7 Improvement	11
6.8 Registered trademark	11
6.9 Resale	12
6.10 Relocation	12
6.11 Reproduction of documents without permission	12
6.12 Establishment date	12
7. Preparations and installation	13
7.1 Scope-of-responsibility when Yamaha contracts the transport company	13
7.1.1 Unloading the product	13
7.1.2 Transportation within factory site	13
7.1.3 Securing a delivery route	13
7.1.4 Dew condensation prevention	13
7.1.5 Transport crate disposal	13
7.2 Scope-of-responsibility when the transporter is contracted by the distributor and customer	14
7.3 Preparations for power source and air supply source	14
7.4 Securing environmental conditions	14
7.5 Network	15
7.6 Anti-virus measures	15
8. Inspection and acceptance	16
8.1 Inspection before shipment	16
8.2 Inspection after installation	16
8.3 Acceptance	16

9. Warranty	17
9.1 Warranty period	17
9.2 Warranty coverage and contents	17
9.3 Exception to warranty	18
10. Safety	19
10.1 Overview	19
10.2 Ensuring the safety	19
10.3 Warning labels	20
10.4 Cautions regarding equipment openings and gaps, etc.....	21
10.5 CE marking.....	22
11. Main Specs.	23
11.1 Outline dimensions	23
11.2 Weight	23
11.3 Air supply source	23
11.4 Air connection coupler (Attached to the main body)	24
11.5 Air consumption flowrate	24
11.6 Power supply	24
11.7 Noise level	25
11.8 Ambient environment	25
12. Basic Performance	27
12.1 Dispensing tact	27
12.2 Dispensing accuracy	27
12.3 Dispensing head	27
12.4 Compatible board dimensions.....	28
12.5 Dispensing-prohibited range	30
12.6 Compatible board thickness.....	30
12.7 Compatible board weight	30
12.8 Recommended board material	30
12.9 Compatible board's permissible warp	30
12.10 Board slits & holes.....	31
12.11 Compatible board's component restrictions	31
12.12 Board's conveyance speed	31
12.13 Board's conveyance height	31
12.14 Conveyor belt for board's conveyance	31

12.15	Input data	32
12.16	Minimum positioning setting resolution	32
12.17	External interface	32
12.18	Internal memory	32
12.19	External memory	32
13.	General Specifications	33
13.1	Safety design	33
13.2	Emergency stop system & error detection system	33
13.3	Temporary stop (interlock) system & error detection system	33
13.4	Machine status indicators.....	33
13.5	Basic machine operation	34
13.6	Operation screen & operation manual language	34
13.7	Servo controlled axes configuration	34
13.8	Conveyor motor configuration	34
13.9	Other motors configuration	35
13.10	Vision system (image recognition)	35
13.10.1	Fiducial camera	35
13.11	Signal specifications	36
13.11.1	Inter-device signal specifications (Between this machine and the next-process machine)	36
13.11.2	Inter-device signal specifications (Between this machine the previous-process machine)	38
13.12	Syringe remaining level detection	40
14.	Reference & Details	41

4. After-sales service (Japanese market)

When the equipment is installed in Japan, six kinds of after-sales service plans that are conducted by YAMAHA about one year after installation of the equipment are available as described below according to the customer's requests and the specifications of the target machine units.

Availability	Class	Name	Target	Work schedule at site	Periodic after-sales call	Discount right
	YAMAHA's machine is installed for the first time.	Plan S	Normal machine specifications	Three days	One month/Two months/Three months	One-year inspection
		Plan Si	IT option specifications	Three days	One month/Two months/Three months	One-year inspection
	YAMAHA's machine has already been installed.	Plan A	Normal machine specifications	Two days	One month/Two months/Three months	One-year inspection
		Plan Ai	IT option specifications (first time)	Four days	One month/Two months/Three months	One-year inspection
		Plan Bi	IT option specifications (second or subsequent time)	Three days	One month/Two months/Three months	One-year inspection
		Plan C	Normal machine specifications (cost reduction plan)	one day	One month/Two months/Three months	One-year inspection

- * The contents of the work schedule at site are that YAMAHA installs and adjusts the relevant machine and follows up the customer's production start-up.
- * The after-sales call is supported from the call center of YAMAHA's CS Section SMT Group.
- * The one-year inspection(charged base) is announced from your distributor or special agent when ten months have elapsed after installation of the machine.

When the customer requires the one-year inspection, the schedule is adjusted, the telephonic diagnosis is conducted, and the one-year inspection is carried out in the 12th to 14th month after installation of the machine. At this time, the basic work cost is specially discounted (limited time offer).

- * The work beyond the scope of the one-year inspection is estimated separately.
- * After the after-sales service shown above has been expired, YAMAHA will offer the periodic maintenance service or individual after-sales service that is proposed separately.

5. Scope of construction work and service

The following table describes the work allocation between the customer and YAMAHA. Actually, this table summarizes the scope of the construction work, service, and utility. So, the customer needs to check this table.

No.	Item	YAMAHA	Customer	Remarks
01	Design and manufacture of machine units	○		
02	Transportation of product			
03	Unloading of product			
04	Transportation inside work site			
05	Dew condensation prevention		○	
06	Securing of transportation route		○	
07	Preparations for power source and air supply source		○	Including connections to target products
08	Network		○	Including anti-virus measures
09	Installation environment		○	Including foundation construction work
10	Inspection before shipment	○		Including preparations for materials when YAMAHA's standard attendance inspection is conducted.
11	Installation and adjustment work	○		
12	Inspection after installation	○		Including preparations for materials when YAMAHA's standard attendance inspection is conducted.
13	Operation training	○		
14	Safety management		○	
15	After-sales service	○		

* If there are items other than YAMAHA's standard items, such as changing of attendance inspection conditions, they shall be informed beforehand and discussed separately.

6. Preconditions

6.1 Effective area

This specification assumes that YAMAHA MOTOR Co., Ltd. (hereafter referred to as “YAMAHA”) or an association entrusted by YAMAHA is an interested party in Japan
In a foreign country outside Japan, the contract concluded by the overseas distributor and customer takes precedence over this specification. So, the contents of this specification become the reference information.

6.2 Export control by the Foreign Exchange and Foreign Trade Control Law

Products and technologies described in this specification are applicable to the control defined in Japanese Security Trade Control Laws, such as Foreign Exchange and Foreign Trade Control Law. So, such laws should be observed strictly. Even when YAMAHA submits the Certificate of Non-Applicability (parameter sheet) about the products and technologies described in this specification to your company, your company shall be held responsible for judgement of the final non-applicability. Additionally, when the specifications of the products and technologies described in this specification are changed or when the products or technologies are built-into other products, this Certificate of Non-Applicability cannot be used.

6.3 Re-export control by the U.S. Government

The products, technologies, and software described in this specification may include U.S. origin products. Therefore, the re-export control by the U.S. Government shall be observed strictly.

6.4 European region

To export the product to a European country, it is necessary that the product shall conform to the EC machine directives and EMC directives (CE marking compliance).
For details, see “10.5 CE marking” described later.

6.5 Intellectual property right

The contents described in this specification explain the product specifications.
YAMAHA does not warrant or permit the operation of a third person’s intellectual property right or other rights.

6.6 Industrial machine dedicated to indoor use

The product described in this specification is an industrial machine dedicated to indoor use. For operation of the product, various detailed conditions that are described later shall be confirmed.
In particular, the descriptions regarding the safety shall be read thoroughly to strictly observe them.

6.7 Improvement

The contents described in this specification are subject to change without prior notice due to continual improvement of the product or software.

6.8 Registered trademark

Microsoft, Windows, and Excel are registered trademarks of Microsoft Corporation in the United States and/or other countries.

6.9 Resale

When the owner of the product is changed after relocating or reselling the product described in this specification or the product is relocating the product to another country, the after-sales service and warranty contents become invalid afterwards.

If the after-sales support is required, the after-sales support service can be continued by concluding the service contract with our company or one of our distributors.

6.10 Relocation

Please contact YAMAHA or your distributor prior to relocating the product to another country, even if the product ownership remains unchanged. YAMAHA will investigate to determine the appropriate relocation work, and will check to see how the relocation will affect the after-sales service and warranty content. Please note that all after-service and warranty content becomes invalid if the product is exported to another country.

If desiring a continuation of after-service in such cases, a new service contract must be made with the local distributor.

6.11 Reproduction of documents without permission

No part of this specification may be reproduced (copied) without written permission of YAMAHA.

6.12 Establishment date

This specification describes the contents established as of November, 2022.

7. Preparations and installation

When the customer arranges a transportation company, be sure to thoroughly understand the responsible area (conditions) and make the judgement.

See section “7.1” to “7.1.5”, Responsible area when YAMAHA arranges the transportation company.

See section “7.2”, Responsible area when the distributor or customer arranges the transportation company.

7.1 Scope-of-responsibility when Yamaha contracts the transport company

The YAMAHA-specified transport company ships the product from YAMAHA to the site specified by the customer.

7.1.1 Unloading the product

To unload the product, the transportation company designated by YAMAHA unloads the product using heavy machines, such as forklift, crane, and car gondola prepared by the customer.

If the customer is difficult to prepare heavy machines, contact YAMAHA at least one month before the delivery date.

7.1.2 Transportation within factory site

To transport the product within the customer’s factory site, YAMAHA or the transportation company designated by YAMAHA transports the product to the installation place at YAMAHA’s own risk. If the customer unloads and transports the product for some reason, this shall be conducted at the customer’s own risk.

7.1.3 Securing a delivery route

A delivery route necessary to transport the product is secured. In particular, securing of the opening width, elimination of stepped portions, securing of the installation place, and relocation of other equipment are conducted at the customer’s own risk. For details regarding the opening size, see section 11. "Main Specs."

7.1.4 Dew condensation prevention

To transport the product from a cold environment (about 10°C or less) to a temperature regulated environment, such as clean room (about 20°C or more), it is necessary to install the product while gradually balancing the product temperature so as to prevent dew condensation.

In this case, a temporary placing space suitable for the temperature balancing work needs to be secured.

However, when a truck with the temperature regulation function is used, this temperature balancing work is not needed. When the customer requests this type of truck, YAMAHA will arrange it.

7.1.5 Transport crate disposal

After the transportation has been completed, the transportation company designated by YAMAHA collects the waste packing materials, hand lifters, and curing materials.

On the delivery date, the transportation company’s staffs wait until completion of the production line startup work (waiting at local site until 16:00).

7.2 Scope-of-responsibility when the transporter is contracted by the distributor and customer

The product is delivered to the customer at the shipping place of YAMAHA's factory.

The transportation work from loading the product onto the truck to delivery at the local installation place is the responsible area of the company that arranges the transportation company. Therefore, be sure to attend the work from loading the product onto the truck to delivery at the local installation place.

- * The quantity check of the accessories shall be conducted before loading the product onto the truck (when both parties' responsible personnel attend).
YAMAHA shall not be held responsible for missing or damaged accessory during transportation.
- * When suspending the machine by a crane, etc., always use a gondola.
(Attaching suspension wires/belts directly to the machine could cause machine damage.)

7.3 Preparations for power source and air supply source

The customer shall complete the air supply source and power source construction work before the delivery work. The customer connects the air supply source and power source to the product at the customer's own risk. For details, see section 11. "Main Specs."

7.4 Securing environmental conditions

For details regarding the installation environment for the applicable products, see section 11. "Main Specs.".
The customer needs to secure various environmental conditions before the delivery work.

- * There are various conditions, such as temperature, humidity, altitude, atmosphere, floor conditions, ambient noise, ambient illumination, immunity (electro magnetic noise resistance), and emission (electro magnetic noise emission).

7.5 Network

For operation of the product connected to the network, it is preconditioned that the product is operated in the closed network environment that consists of only the product and offline PC prepared by the customer. When connecting the product to the customer's in-factory or an external network, the customer shall be held responsible for such connection work.

YAMAHA shall not be held responsible for any defect arising from the network setting or network connection if the product is connected to a network other than that consisting of only the product and offline PC.

7.6 Anti-virus measures

The product uses embedded Microsoft Windows dedicated to industrial machines. On the other hand, it is already known that there are many computer viruses that attempt invading Windows systems. From this background, YAMAHA takes the following measures for the product.

According to the reasons shown below, YAMAHA does not take any anti-virus measures.

-1- Protection of system area by Write Filter

The system data of Windows is stored into an area protected by a function called "Write Filter". Even if a computer virus invades and writes the system data, this data is not saved and the system data is restored to that before computer virus infection when the power is restarted. (This does not function if the Write Filter function is set disabled.)

-2- Insensitivity to computer virus infection by originally developed data format (non-sensitized)

Normally, the computer virus infects a general format data file. So, it is thought that the infectivity becomes extremely low for YAMAHA's original data that is used for the product. Even if the data is infected, the data can be restored by reinstalling the application programs and backup data.

-3- Virus check before shipment

The virus check of the product is performed in YAMAHA's shipping inspection. When the virus infection is not detected and the product is considered as correct, the "Checked" label is affixed to the USB port.

-4- Reminder not to use USB flash memory with computer virus infection risk

A virus-checked dedicated USB flash memory for data backup is supplied with the product. A generally available USB flash memory, the virus infection of which has not been checked, shall not be used.

-5- Recommendations for operation in local network

YAMAHA warrants only the operation in the "closed network" that consists of the product and offline PC prepared by the customer. This prevents virus infection unless the product is connected to the customer's office LAN or an external internet.

When the customer connects the product to the office LAN at the customer's own risk, it is recommended to take anti-virus measures, such as installation of two LAN cards into offline PC and separation of the network system using different IP addresses, installation of generally available anti-virus software and Microsoft's patch programs, or stopping of Computer-Browser service.

-6- Correction patch programs disclosed by Microsoft do not apply to the product.

Since the product uses embedded Microsoft Windows dedicated to industrial machines, patch programs intended for general PC OS that are disclosed by Microsoft do not apply to this product. Note that these patch programs can be installed into the customer's offline PC.

-7- Software other than that specified (application or system software) cannot be installed.

Software specified for the target product is only OS (operating system) that is a basic program for the machine and application program that provides mounter functions. Any software other than that specified cannot be installed into the product. YAMAHA shall not be held responsible for any defect arising from installation of other software.

8. Inspection and acceptance

8.1 Inspection before shipment

The product is inspected with the customer attended at YAMAHA's factory before shipment. After this attendance inspection is considered as accepted, the product is shipped to the factory site designated by the customer.

The following describes the inspection items, inspection methods, and acceptance criteria.

-1- Inspection items

Units and quantities making up this equipment and other conditions stated in the delivery specification shall be satisfied.

-2- Inspection methods

The dispensing test is performed using the materials under the conditions described below.

Witnessed test boards	YAMAHA test boards	Customer boards * If customer's PCBs are to be used, the PCBs and coordinate data (and dispensing fluids, where applicable) must be provided to YAMAHA 2 weeks prior to the test date
Witnessed test materials	YAMAHA's standard glue used for evaluations. Accessory nozzles. * As a rule, the above materials are provided by YAMAHA.	* Separate consultation is required in cases where customer materials are used, and in cases where the test involves customer PCBs and dispensing fluids.
Test quantity	Total of 2000 or more points.	
PASS criterion	There shall be no dispensing errors during the test. * The test content may vary according to the specs. of the device in question.	

8.2 Inspection after installation

After "8.1 Inspection before shipment" has been considered as accepted, the product is shipped to the factory site designated by the customer and the delivery work is conducted. After the installation and adjustment work have been completed at the installation site, the inspection with the same contents as described in "8.1 Inspection before shipment" is performed. This inspection is called "Inspection after installation".

8.3 Acceptance

In the same manner as "8.1 Inspection before shipment" described above, when the results of "8.2 Inspection after installation" satisfy the acceptance criteria, the product is considered as accepted.

9. Warranty

9.1 Warranty period

The warranty period of the product ends when any of the following applies (whichever comes first).

- 1- One year elapses from the time of acceptance.
- 2- 18 months elapse from the time of shipment from YAMAHA's factory
- 3- Total operation hours reach 5,000 hours.

9.2 Warranty coverage and contents

The following describes the warranty coverage and contents.

- 1- The warranty coverage of the product is the portions that are described as normal contents of this delivery specification, that is, the contents stated in "1. Machine configuration" and "3. Arrangements". The warranty coverage does not include the contents of "2. Custom-order specifications and specific items". The warranty coverage of the custom-order specifications and specific items shall be discussed separately.
- 2- If any defect or trouble due to YAMAHA's design or workmanship is found in machine unit, software, or genuine part, that has been delivered to the customer's factory using proper procedures and considered as accepted, during the warranty period, YAMAHA shall repair or replace the defective unit, software, or genuine part free of charge.
- 3- YAMAHA shall not accept the customer's compensations for any incidental or consequential losses, losses due to absence from work, faulty product production, cost losses, and sales opportunity losses (lost earnings).
- 4- If the customer receives a claim regarding compensations for losses due to infringement on patent right, intellectual property right, or other right resulting from use of products that the customer has manufactured using this equipment, software, and genuine parts from a third party, YAMAHA shall not accept the customer's compensations.
- 5- The contents described in this specification explain the specifications of this equipment. YAMAHA does not warrant or permit the operation of a third person's patent right, intellectual property right or other rights.

9.3 Exception to warranty

The coverage of this warranty does not include the following terms even during the warranty period.

- 01- Defects arising from earthquake, tsunami, lightning, wind or flood damage, or other natural disaster or force majeure.
- 02- Malfunctions and damages arising from fire, pollution, salt damage, dew condensation, or unusual voltage.
- 03- Defects arising from collision, fall, drop, or other accident.
- 04- Deteriorations or defects arising from secular change.
Example: Paint or plated portion is discolored or rusted.
- 05- Defects arising from worn-out consumable part during normal operation.
Example: Deterioration of consumable parts specified in separate manuals (user's and maintenance manuals, and component drawing and list).
- 06- Sensuous symptoms, such as sound or vibration that do not adversely affect the quality and functions. (Unusual noise or excessive vibration is handled separately.)
Example: Controller operation sound or motor rotation sound.
- 07- Defects arising from environmental conditions.
Example: Defects arising from air supply source including impurity, oil mist, dew condensation, or dust or dirt in the atmosphere.
- 08- Defects arising from improper environmental conditions, or secular change or deterioration of environmental conditions.
Example: Equipment vibration arising from installation floor surface with insufficient strength or defects arising from inclination or deformation of installation floor surface.
- 09- Defects arising from negligence, misuse, or mistake of correct operation procedures instructed in the manuals.
- 10- Defects arising from negligence, incomplete steps, mistake of inspection and maintenance procedures instructed in the manuals.
- 11- Problems which occur due to the use of non-YAMAHA components (e.g., nozzles).
- 12- Defects arising from use of lubricants (oil and grease, etc) other than those specified.
- 13- Defects arising from modification or specification change made by the customer.
- 14- Defects arising from repair or maintenance work made by personnel other than YAMAHA's engineers or those specified by YAMAHA.
- 15- Defects arising from careless storage at the customer's factory or warehouse during the storage period.
- 16- Defects arising from movement, relocation, or resale without prior notification to YAMAHA after completion of the acceptance inspection.
- 17- Defective parts that have been replaced free of charge are not returned to the place specified by YAMAHA within 30 days.

* To locate the cause of the trouble, it is necessary to investigate the defective parts. So, please return the replaced parts as soon as possible.

10. Safety

10.1 Overview

This equipment is an industrial machine dedicated to indoor use only.

To ensure that the machine you purchased is used safely and correctly, always comply with the instructions and rules in manual regarding safety.

To maintain the safety of the operator or person working with this machine, it is essential that it be installed correctly in compliance with the safety standards and conditions of that country.

Complying with the safety regulations and laws of that country is the responsibility of the customer who purchased this machine. The supervisor of this machine must take responsibility to ensure all measures have been taken for machine safety.

10.2 Ensuring the safety

The following describes typical safety instructions, such as warnings and cautions to ensure the safety. For details, check the manuals.

WARNING

Indicates a potentially hazardous situation which, if not avoided, could result in death or serious injury. These are points most essential for protecting the safety of the machine operator, inspector and service personnel.

Pictorial symbol put down with warning messages



== Examples of warning messages ==

- Never allow any part of your body (hand or head, etc.) to enter within the machine movement range during operation.
- Safety devices (safety interlocks) that stop machine operation should always be in good operating condition.
- Always shut off the power and air supply before replacing parts or performing repairs.
- During teaching or when making machine adjustments, always keep alert so that you can stop the machine whenever needed.

CAUTION

Indicates a potentially hazardous situation which, if not avoided, may result in minor injury, or material loss or damage to the machine. These points are important for protecting the safety of the machine and data, etc.

Pictorial symbol put down with caution messages



== Examples of caution messages ==

- The work person operating the machine must have been trained in correct machine operation and safety.
- If the component supply unit is installed without stopping the machine, this may cause a part of your body to be entangled in the machine.

10.3 Warning labels

To use the YAMAHA machines safely and correctly, warning labels are attached to the machine body and peripheral equipment. Check that the information on each warning label is clearly legible and comply with the instructions.

The following 3 types of marks are used on warning labels. Each mark has its own meaning and is typically used with a pictogram to emphasize the message.

Mark and pictogram

Marks and examples used with pictogram



	Definition	Shape/Color	Meaning of the above examples
Warning	Indicates a hazard, how to avoid the hazard, and potential consequences of ignoring the warning.	Yellow triangle with black border. Pictogram is black on yellow.	Risk of electrical shock
Prohibition	Indicates a prohibited action to avoid the potential hazard.	Red circle with slash. Pictogram is black and located behind slash.	Do not modify or disassemble safety cover switch.
Instruction	Indicated an action that must be taken to avoid the potential hazard.	Blue circle. Pictogram is white on blue.	Read the manual to understand procedure before starting operation.

10.4 Cautions regarding equipment openings and gaps, etc.

Depending on the application and operating conditions, openings and gaps may occur at the equipment's moving areas, posing a hazard to personnel hands, etc., which could possibly be inserted and trapped there. As a safety measure for such hazards, the following optional equipment should be used.

◎ Safety part for board conveyor IN and OUT ports.

Muzzle plate: conveyor safety cover

⇒ See section 1. “Machine Configuration”, Muzzle plate

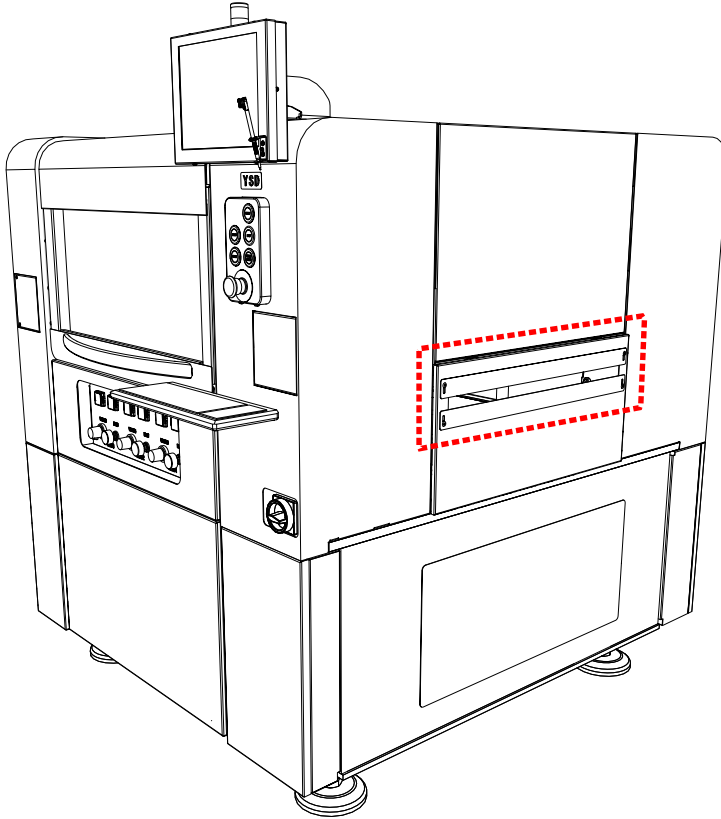

10.5 CE marking

This equipment conforms to the EU Machinery Directive 2006/42/EC (*1) and EMC Directive 2014/30/EU (*2).

However, this equipment does not bear CE marking if a custom-order item (with the special specifications) was installed.

*1 Cautions regarding the official language of EU countries and the language used in operation manuals, CE declarations, operation screen characters, and warning labels when this equipment is installed in an EU country.

Warning labels only have pictograms or else include warning messages in English, Chinese, Korean and Japanese language.

*2 Description of EMC (Electro Magnetic Compatibility)

- Electromagnetic immunity (Immunity)

Complies with test standards as specified by EN 61000-6-2.

- Electromagnetic emissions (Emission)

Complies with test standards for ISM category: Group 1, Class A, as specified by EN 55011.

Class A equipment is intended for use in industrial environments. If used in other environments, ensuring electromagnetic compatibility (EMC) might be difficult. Refer to EN 55011 standards for detailed information.

11. Main Specs.

11.1 Outline dimensions

L1,254 × W1,419 × H1,445mm (main unit only)

* For dimension details and dimensions with options installed, see the figs. below.

* The figs. below shows the dimensions with various options installed.

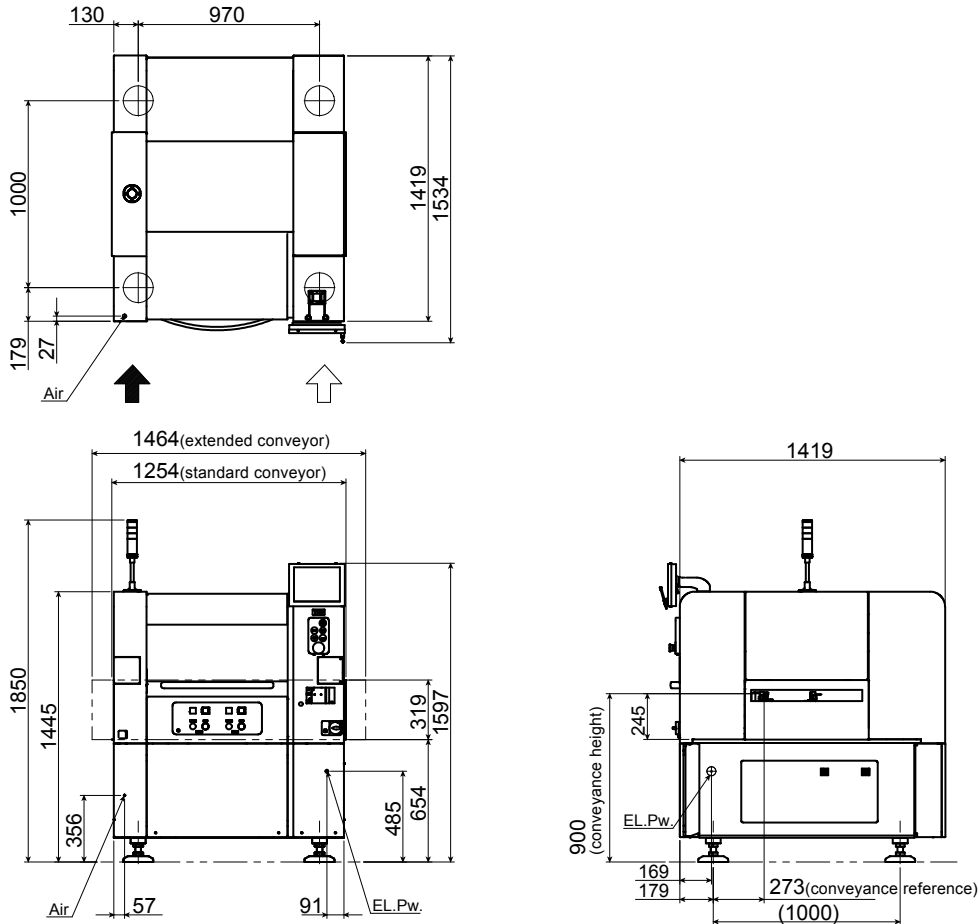

11.2 Weight

Approx. 1,250 kg (main unit)

11.3 Air supply source

0.45MPa or higher (4.5kgf / cm² or higher), clean and dry air

- * Use an air supply hose with an inner diameter of 8mm or larger to ensure an adequate air flowrate.
- * Install an air dryer and line filter in the air supply source line to ensure that good quality air is supplied. (The purpose of the air filter inside this machine is only to protect the machine itself. It is important that the air supplied from the customer's air source line also be kept clean and dry in order to ensure that the functions and performance of this machine are maintained over a long period.)

11.4 Air connection coupler (Attached to the main body)

NITTO's HI-CUPLA 30SH socket side

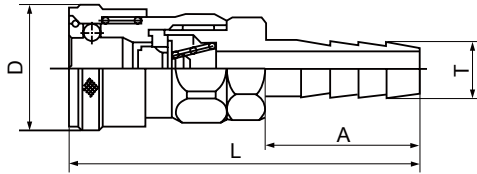

D : ϕ 26.5mm T : ϕ 11.3mm L : 76.5mm A : 34mm

* To maintain a sufficient air flow rate, use 3 / 8-inch air hose (inside diameter is ϕ 8 mm or more).

11.5 Air consumption flowrate

70L / min (ANR) (Average consumption amount for basic model under standard operating conditions)

80L / min (ANR) (Max. momentary flowrate of basic model)

* "ANR" is an acronym for the French term "Atmosphere Normal de Reference" (standard reference atmospheric conditions). This condition is defined as a temperature of 20°C, relative humidity of 65%, absolute pressure of 101.3kPa (1.03kgf / cm²) or 760mmHg).

11.6 Power supply

- 01- Compatible types : 3-phase 200VAC / 208VAC / 220VAC / 240VAC / 380VAC / 400VAC / 416VAC \pm 10%
- 02- Frequency : 50Hz / 60Hz
- 03- Capacity : 7.0kVA
- 04- Average power consumption : 0.55kVA (under standard operating conditions)
- 05- Power cable : Cross-sectional area of each phase conductor: 3.3mm² or larger
- 06- Power cable terminal size

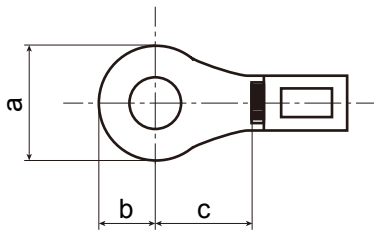

Terminal Part No.	KMG-M643A-00
Manufacturers	TOYOGIKEN CO.,LTD
Manufacturers Part No.	FPS-40
Bolt diameter	M4
Max. Terminal width (a)	9.5 mm
Max. Terminal length (b)	5 mm
Min. Terminal length (c)	6 mm
Tightening torque	1.2-1.8N · m

- 07- Other:
 - <1> To prevent electric shocks, be sure that the power source is shut off when connecting the power supply.
 - <2> Be sure to securely connect the main unit's ground wire.

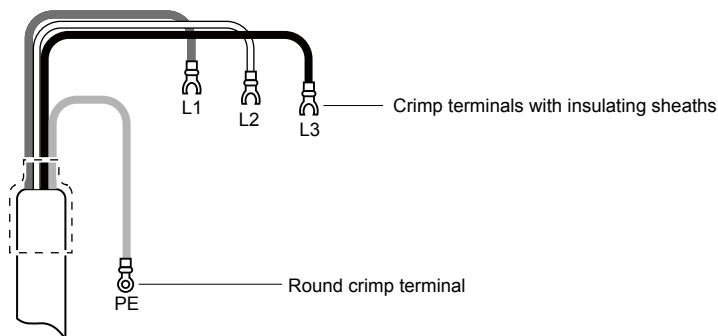

- * In order to prevent electric shocks, always turn the source power OFF before connecting electrical wiring.
- * Be sure that the main unit's ground cable is securely grounded.
- * L1, L2, L3 are 3-phase AC power cables, and PE is the ground cable.

11. Main Specs.

YSD (SESLR13700-19) v2.019

11.7 Noise level

78dB (A) or lower

11.8 Ambient environment

- 01- Temperature 15 to 35°C (functional guarantee)
20 to 28°C (precision guarantee)
- 02- Humidity 20 to 80%, no condensation (permissible range)
50 to 60% (Optimal range)
 - * A condition of 40% or higher should be maintained to prevent electrostatic charges.
 - * When using an industrial humidifier, always use pure (deionized) water.
 - * When the ambient temperature rises more than the surface of the machine, dew condensation might occur under the condition described below.
Note that dew condensation may cause the machine to break down.

Condition of Dew Condensation

Dew condensation might occur when the “Differences between Ambient and Surface Temperatures of Machine” reach the values or more in the table below.

Humidity (%)	Differences between Ambient and Surface Temperatures of Machine (Ambient Temperature > Surface Temperature)
80	3 °C or more
70	6 °C or more
60	8 °C or more
50	10 °C or more
40	14 °C or more
30	18 °C or more

- 03- Transient voltage category Category III
- 04- Degree of contamination Degree 2
- 05- Atmosphere <1> Free from dust, etc.
<2> Free from organic solvent vapor, sulfurous acid gas, chlorine gas, and flammable gas.
- 06- Elevation Do not use at altitudes exceeding 1,000m above sea level.
 - * To prevent the insulation performance from being adversely affected by the atmospheric pressure and cosmic rays.

-07- Installation site floor requirements

<1> The floor's load strength must be capable of supporting a weight of approximately 850kg / cm² or more.

* Regarding the floor's load strength, please consult with a qualified professional who is familiar with the installation site. At that time, be sure to provide the professional consultant with information regarding the equipment weight, floor footprint, and adjustable feet positions, etc.

<2> The floor must be level, and strong enough to prevent vibration during equipment operation. A concrete floor, or a floor with a strength equivalent to concrete, is required. Unacceptable floors include wood floors, typical office floors, and grating floors (gutter cover gratings, etc.).

* For non-concrete floors, consult with a professional who is familiar with the installation site in order to determine the best way to reinforce the load-bearing positions where the equipment's adjustable legs (feet) will be located.

-08- Ambient noise

<1> Free from loud noises.

<2> The equipment's operation sounds and warning buzzers, etc., must be audible over the ambient noise.

-09- Ambient lighting

Strong sunlight, etc., must not be shining on the vision system (optical image processing system).

-10- Immunity / electromagnetic noise resistance, or electromagnetic susceptibility

Refer to section 10.5 "CE Marking".

-11- Emission / electromagnetic noise generation, or electromagnetic interference

Refer to section 10.5 "CE Marking".

12. Basic Performance

12.1 Dispensing tact

0.07 sec / shot * Under optimal YAMAHA conditions

12.2 Dispensing accuracy

$\pm 0.05\text{mm} (\mu + 3 \sigma)$ * Under optimal YAMAHA conditions

12.3 Dispensing head

Item	Specification
UP/DOWN drive format	AC servo motor
Rotation drive format	AC servo motor
Dispensable materials	Various types of glues and solder paste
Dispensing accuracy	$\pm 0.05\text{mm}$ (1-point dispensing, dispensing angle : 0°)
Dispensing angle	0° to 180° (setting units : 0.001°)
Dispensing diameter	$\phi 0.5$ to $\phi 2.5$
Temperature control	Room temp. to room temp. +20°C (Max. 50°C) Nozzle temp. regulation
Syringe	Standard compatibility with Musashi Engineering, Iwashita Engineering, EFD brand 30cc syringes * Syringe interior must be completely free of bubbles
Dispensing type	For glue : 2-point dispensing, 1-point dispensing For solder paste : 1-point dispensing

12.4 Compatible board dimensions

Minimum board dimension : L50 × W50mm

Maximum board dimension : Varies according to the selected head and board conveyance specifications.
See the table below.

* “L” denotes the board conveyance direction, and “W” denotes the direction which is at right-angles to the board conveyance direction.

* Machine layout types, See section 14. ”Reference & Details / Layout list”

2 heads (standard)

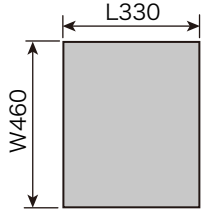
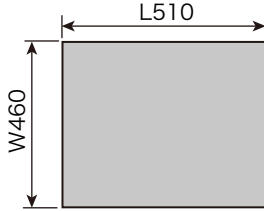
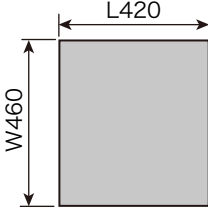
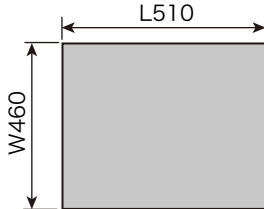
Standard conveyor (without extension : machine's outer dimension is L1,254mm)			
For 3-boards conveyance specs.		1-board conveyance specs.	
 <p>* Max. “L” is 460mm when conveying 1 board with 3-boards conveyance specs.</p>			
Machine layout types			
Conveyor IN port : right side	Conveyor IN port : left side	Conveyor IN port : right side	Conveyor IN port : left side
#001 #051	#011 #061	#002 #052	#012 #062
Extension conveyor (with extension : machine's outer dimension is L1,464mm / optional)			
For 3-boards conveyance specs.		1-board conveyance specs.	
 <p>* Max. “L” is 460mm when conveying 1 board with 3-boards conveyance specs.</p>			
Machine layout types			
Conveyor IN port : right side	Conveyor IN port : left side	Conveyor IN port : right side	Conveyor IN port : left side
#004 #054	#014 #064	#005 #055	#015 #065

* sub-stopper (optional) is required for 3-board conveyance.

3 heads (optional)

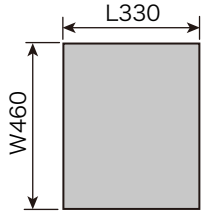
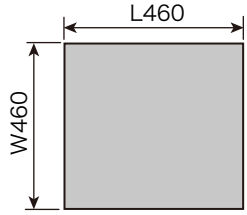
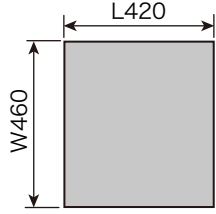
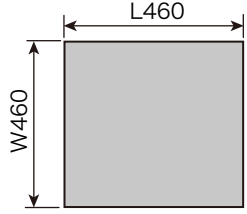
Standard conveyor (without extension : machine's outer dimension is L1,254mm)			
For 3-boards conveyance specs.		1-board conveyance specs.	
 <p>* Max. "L" is 460mm when conveying 1 board with 3-boards conveyance specs.</p>			
Machine layout types			
Conveyor IN port : right side	Conveyor IN port : left side	Conveyor IN port : right side	Conveyor IN port : left side
#003	#013	#003	#013
#053	#063	#053	#063
Extension conveyor (with extension: machine's outer dimension is L1,464mm / optional)			
For 3-boards conveyance specs.		1-board conveyance specs.	
 <p>* Max. "L" is 460mm when conveying 1 board with 3-boards conveyance specs.</p>			
Machine layout types			
Conveyor IN port : right side	Conveyor IN port : left side	Conveyor IN port : right side	Conveyor IN port : left side
#006	#016	#006	#016
#056	#066	#056	#066

* sub-stopper (optional) is required for 3-board conveyance.

12. Basic Performance

YSD (SESLR13700-19) v2.019

12.5 Dispensing-prohibited range

As shown in the illustration below, dispensing is not possible at some areas of the board due to interference with the conveyor rails and the board clamping claws. Moreover the 30mm linear zone represented by “Cx” is required for contact with the stopper.

The “Cx” zone changes (C1 / C2 / C3 / C4) according to the machine configuration (conveyor type, board conveyance direction, conveyor reference).

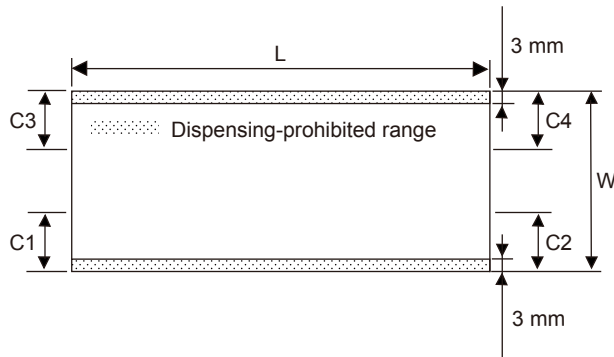

Patterns

C1 : For RIGHT to LEFT conveyance & FRONT reference

C2 : For LEFT to RIGHT conveyance & FRONT reference

C3 : For RIGHT to LEFT conveyance & REAR reference

C4 : For LEFT to RIGHT conveyance & REAR reference

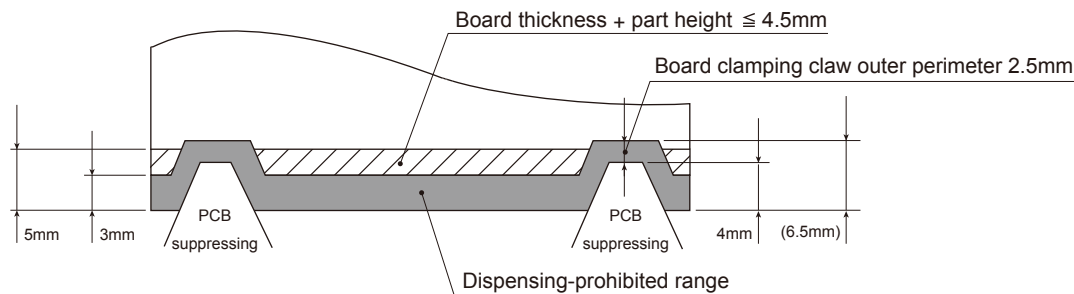

12.6 Compatible board thickness

0.4 to 3.0mm

12.7 Compatible board weight

0.65kg / sheet or less

* Consultation required for board weights exceeding 0.65kg.

12.8 Recommended board material

Glass fiber reinforced epoxy resin

* Separate consultation required for other materials.

12.9 Compatible board's permissible warp

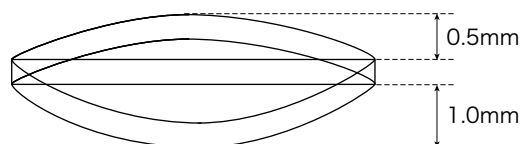

Upward warp : 0.5mm or less

Downward warp : 1.0mm or less

* Warps which exceed the above values (particularly the upward warp) will dramatically reduce the dispensing accuracy. Moreover, an excessive warp could cause interference with the head, nozzle, or camera. To avoid this, check the board's warp carefully.

12.10 Board slits & holes

The conveyor is equipped with sensors (light transmission type) to check the position of boards being conveyed. Therefore, this position detection may not be possible for boards which have slits and holes. Separate consultation is required for such boards.

12.11 Compatible board's component restrictions

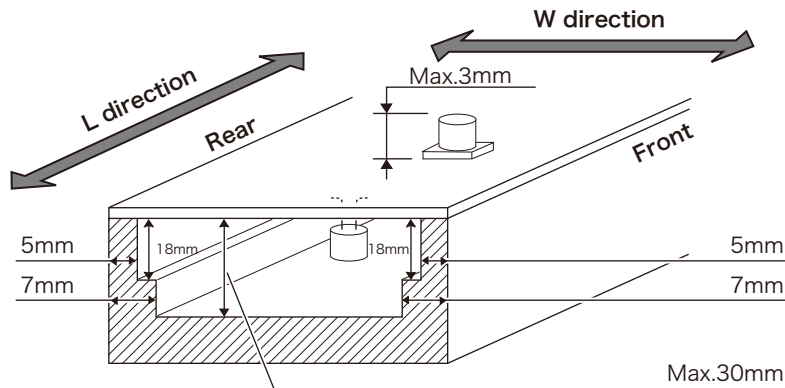

The height of the board's top-face components must not exceed 3mm.

* There must be no components within 3mm of the board's conveyance direction edges.

⇒ See the illustration shown in section 12.5 "Dispensing-prohibited range"

The height of the board's bottom-face components must not exceed 30mm.

* Shaded portions shown in the illustration below do not permit the presence of components.

12.12 Board's conveyance speed

50 to 450mm / sec (variable by setting)

* The conveyance speed may change if the board's weight is increased or decreased, etc.

12.13 Board's conveyance height

900mm ± 10mm (Measured from floor to conveyor belt's top surface)

12.14 Conveyor belt for board's conveyance

Conveyor belts for transporting boards have antistatic specifications, and the surface resistance values are as follows.

Surface resistance value (reference value): $1 \times 10^8 \Omega$ to $1 \times 10^{10} \Omega$

Depending on the required level of ESD countermeasures, it is also possible to select board transfer belts with higher electrostatic diffusion (ESD reinforced belts).

The surface resistance value of the ESD reinforced belt is as follows.

Surface resistance value (reference value): $1 \times 10^6 \Omega$ to $1 \times 10^8 \Omega$

12.15 Input data

- 01- Number of dispensing points: 12,800 points (this value may be lower, depending on the number of boards, the number of blocks, and the number of fiducials.)
- 02- Component types: 255 types per board
- 03- Board data: 100MB / unit
- 04- Number of fiducials: 128 sets per board (for 2-point fiducials)
- 05- Input format: By the main unit's accessory input unit

12.16 Minimum positioning setting resolution

X-axis / Y-axis / Z-axis: 0.001mm
R-axis: 0.001°

12.17 External interface

LAN *1 port (See section 7.5 "Network", and 7.6 "Anti-virus measures".)

12.18 Internal memory

Internal 4GB Flash Card *1 card

* For saving the OS / mouter application software / board data / component data / vision data / machine information / production history information, etc.

12.19 External memory

USB Flash Memory, 1GB or more * 1 device (Provided as standard item: For data backup)

13. General Specifications

13.1 Safety design

This equipment conforms to the CE marking requirements (EU Machinery Directive 2006/42/EC and EMC Directive 2004/108/EC). However, special-order specifications will not be CE marking compliant. For details, see section 10.5 "CE Marking".

13.2 Emergency stop system & error detection system

To ensure safety, this equipment has the following emergency stop and error detection systems.

No.	System Areas & Items	Registered Name	Installed Status	Remarks
01	Front operation console's Emergency Stop	SB31	◎	Push-lock, turn-reset button
02	Front safety cover	SQ101	◎	Mechanical switch with key
03	Control box servo 1 group	SRV01	◎	Y1 / Y2 / X / PU-axis
04	Control box remote servo 1	P093	◎	W-axis error detection
05	Control box remote servo 2	P043	◎	Heads Z1 to 3 / R1 error detection
06	Y gantry	SQ0021	◎	Y-axis over-travel detection
07	X beam	SQ0022	◎	X-axis over-travel detection

* [Installed status] mark meanings ==> ◎: Present, ✕: Absent, △: Optional

* [Registered names] are the names which appear on the control wiring schematic (YAMAHA Support & Service website) used for maintenance support.

* Other hardware related error detection items include temperature error, fan stop, and power error detection, etc. For details, refer to the Operation Manuals.

13.3 Temporary stop (interlock) system & error detection system

Temporary stop and error detection systems (see below) are provided to protect the machine and for continued operation.

No.	System Areas & Items	Registered Name	Installed Status	Remarks
01	Air pressure	SP11	◎	Air pressure drop

* [Installed status] mark meanings ==> ◎: Present, ✕: Absent, △: Optional

* [Registered names] are the names which appear on the control wiring schematic (YAMAHA Support & Service website) used for maintenance support.

* Other software error detection items include XY axes soft limit setting errors and board conveyance errors, etc. For details, refer to the Operation Manuals.

13.4 Machine status indicators

The equipment status is indicated by the indicator lamps shown in the table below. The lamp color pattern can be selected to conform to regional specifications or to the customer's equipment specifications. Color selection details are given in section [1. Machine Configuration], "Lamp Color Pattern".

No.	Machine Status	Lamp Location	Lamp Color	
			Lamp Color	Yamaha Std.
01	Emergency stop status, safety cover open, CPU-NG, etc.	Top row	White	Red
02	Conveyance error, out of fluid, etc.	Center row	Blue	Yellow
03	AUTO operation in progress	Bottom row	Green	Green

13. General Specifications

YSD (SESLR13700-19) v2.019

13.5 Basic machine operation

This equipment's basic operations are performed by using the operation panel buttons shown in the table below. The buttons' ID color pattern can be selected to conform to regional specifications or to the customer's equipment specifications.

Color selection details are given in section [1. Machine Configuration], "Lamp Color Pattern".

No.	Basic Operation Descriptions	Button Names	ID Color	
			Europe Std.	Yamaha Std.
01	Clearing an Emergency Stop status & servo ON	READY	White	White
02	Data reset or dispensing sequence reset (to beginning)	RESET	White	White
03	AUTO operation start	START	Green	Green
04	AUTO operation stop	STOP	White	Red
05	Clearing an Error Lock status	ERROR CLEAR	Blue	Yellow

13.6 Operation screen & operation manual language

The language used on this equipments operation screens and in the operation manuals can be selected from the following: English, Chinese, Korean, Japanese. Language selection details are given in section [1. Machine Configuration], "Display Language", and in section [3. Ordered Items / -1- Accessories], "Operation Manual Language".

* For details regarding installation in EU countries, refer to section 10.5 "CE Marking".

13.7 Servo controlled axes configuration

Total number of axes: There are a total of 9 servo motor controlled axes.

No.	Areas & Items	Controlled Axis Name	Motor Name	Installed Status	Remarks
01	X beam	Y1	M01	◎	
02	Y gantry, right side	Y2	M02	◎	
03	Y gantry, left side	X	M03	◎	
04	Push-up	PU1	M04	◎	Built-in electromagnetic brake
05	Conveyor width	W	M09	◎	
06	Head 1 UP / DOWN	Z1	M25	◎	
07	Head 2 UP / DOWN	Z2	M26	◎	
08	Head 3 UP / DOWN	Z3	M27	◎	
09	Head 1 / 2 / 3 rotation	R1	M28	◎	
Total number of axes				09	

* [Installed status] mark meanings ==> ◎: Present, ×: Absent, ▲: Optional

* [Motor names] are the names which appear on the control wiring schematic (YAMAHA Support & Service website) used for maintenance support.

13.8 Conveyor motor configuration

Total number of motors : Driven by 1 variable-speed brushless DC motors, depending on the machine configuration.

No.	Areas & Items	Motor Name	Installed Status	Remarks
01	Conveyor		◎	
Total number of motor			1	

* [Installed status] mark meanings ==> ◎: Present, ×: Absent, ▲: Optional

* [Motor names] are the names which appear on the control wiring schematic (YAMAHA Support & Service website) used for maintenance support.

13. General Specifications

YSD (SESLR13700-19) v2.019

13.9 Other motors configuration

Cooling fan motors are used in various locations, including at the control box, motors, cameras, etc.

13.10 Vision system (image recognition)

The vision system shown in the table below is used to recognize parts and board marks. The system layout varies according to the board size, part size, and electrode specifications, etc. See section 1. "Machine Configuration", Fiducial camera.

* An actual component dispensing operation can be affected by other factors in addition to the system's image recognition capability. Determining whether or not a given component can be mounted requires a test operation with an actual sample of the component in question.

13.10.1 Fiducial camera

Item	Remarks
System	Fiducial camera
Installation Area	Head Center
Field of view	8 × 8mm
Application	Fiducial mark detection, bad mark detection, teaching
Mark shape	Round mark ϕ 0.5 to 2mm (Yamaha recommended), square 0.5 to 2mm, diamond-shaped 0.5 to 2mm. The mark surface must not be scratched or soiled. The contrast between the mark and the background board must be adequate (clear contrast). Reflective bodies are permitted at either the mark side or the background side.
Mark surface	Copper foil, metal plating, solder leveler
Background material	Glass fiber reinforced epoxy resin boards are ideal. * Confirmation is required before attempting to use ceramic and polyimide boards (flexible types).
Detection area	The detection area dimensions must be within the field-of-view range, and they are specified by entering their numeric values. (This minimizes wasted vision processing time.)
Scan range	Within an area of 0.2mm from the outer edge of the mark, there must be no resist, silk printing, thru-holes, or patterns, etc., with the same optical characteristics as the mark. The scan-subject's shape must be the only such shape in the detection area. * Specify the detection area so that it contains no similar shapes.
Mark arrangement	Diagonal 2-point or 4-point marks on the board are preferable.

13.11 Signal specifications

13.11.1 Inter-device signal specifications (Between this machine and the next-process machine)

* Next Interface

Select the appropriate signal specifications from the table below in accordance with the operating conditions such as the machine combinations and signal cables, etc.

To be matched with the selection made in section 13.11.2 "Inter-device signal specifications" (between this machine and previous-process machine: Previous Interface).

* When linking this machine to an other-brand machine, the customer is responsible for obtaining the required information regarding that machine's functions, etc.

Selection									
Next Interface This machine's connector AMP: 206043-1 (14-pin receptacle)		GATE signal specs.		Advanced (extension) GATE signal specs.		Advanced (extension) GATE 2 signal specs.		SEMA signal specs.	
		Yamaha machines up to and including the YV generation & other-brand machines		Yamaha machines beginning from the X generation (early X / Xg / YG / YS models)		Yamaha machines beginning from the YS generation *1 From November, 2009		SEMA signal conformance machine	
Pin No.	Category		Signal Name		Signal Name		Signal Name		Signal Name
1	DC +24V		Gate In (com)	Next-process machine board unloading request signal input	Busy In (com)	Next-process machine board loading in-progress signal input	Same as left		SEMA specs.
2	PNP input (ON judgment at +24V)		Gate In (input)		Busy In (input)				
3	Relay contact output	When the relay contact output is ON: Power ON / Closed	Not used		BA Out (output)	This-machine board unloading enabled signal output	Same as left		
4	Relay contact output		Not used		BA Out (output)				
5	Incorrect connection prevention function application	Key-plug filled	Prescribed mating only (blocked)		Prescribed mating only (blocked)		Prescribed mating only (blocked)		
6			Prescribed mating only (reception enabled)		Prescribed mating only (reception enabled)		Prescribed mating only (reception enabled)		
7	DC 0V		Not used		Not used		Not used		
8	Vacant		Vacant		Vacant		Vacant		
9	Relay contact output	When the relay contact output is ON: Power ON / Closed	Not used		UR Out (output)	This-machine AUTO operation in progress signal output	Same as left		
10	Relay contact output		Not used		UR Out (output)				
11	DC +24V		Not used		LR In (com)	Next-process machine AUTO operation in progress signal input	Same as left		
12	PNP input (ON judgment at +24V)		Not used		LR In (input)				
13	DC +24V		Not used *2		Not used *2		LE In (com)	Inter-machine board transfer standby signal input from next- process machine.	
14	PNP input (ON judgment at +24V)		Not used *2		Not used *2		LE In (input)		

*1 The "Advanced GATE 2" specifications are supported by YS generation machines which were shipped beginning from November, 2009. Linking earlier YS generation machines to the line requires modifications to those machines (excluding YS24).

*2 This can be used as a "count reset" signal input. (Waiting for unloader's magazine rack change)

13. General Specifications

YSD (SESLR13700-19) v2.019

- [Gate In] When power is turned ON, this is interpreted as a next-process machine unloading request, and board unloading occurs if this machine's operation is completed. The next-process machine is a relay contact output (dry contact: no-voltage circuit).
- [Busy In] This input signal informs this machine that board unloading is in progress at the next-process machine. The next-process machine is a relay contact output (dry contact: no-voltage circuit).
- [BA Out] This output signal informs the next-process machine that a "board unloading enabled" status exists at this machine.
- [UR Out] This output signal informs the next-process machine that AUTO operation is in progress at this machine.
- [LR In] This input signal informs this machine that AUTO operation is in progress at the next-process machine. The next-process machine is a relay contact output (dry contact: no-voltage circuit).
- [LE In] This input signal is used in systems with Advanced (extension) GATE 2 signal specifications, when the "inter-machine board transfer standby" function is enabled. This input signal informs this machine that a board transfer standby status exists between this machine and the next-process machine. The next-process machine is a relay contact output (dry contact: no-voltage circuit).
The inter-device cable has a yellow marking near the cable connector.

Inter-device signal specifications (Between this machine and the next-process machine)

*** Next Interface**

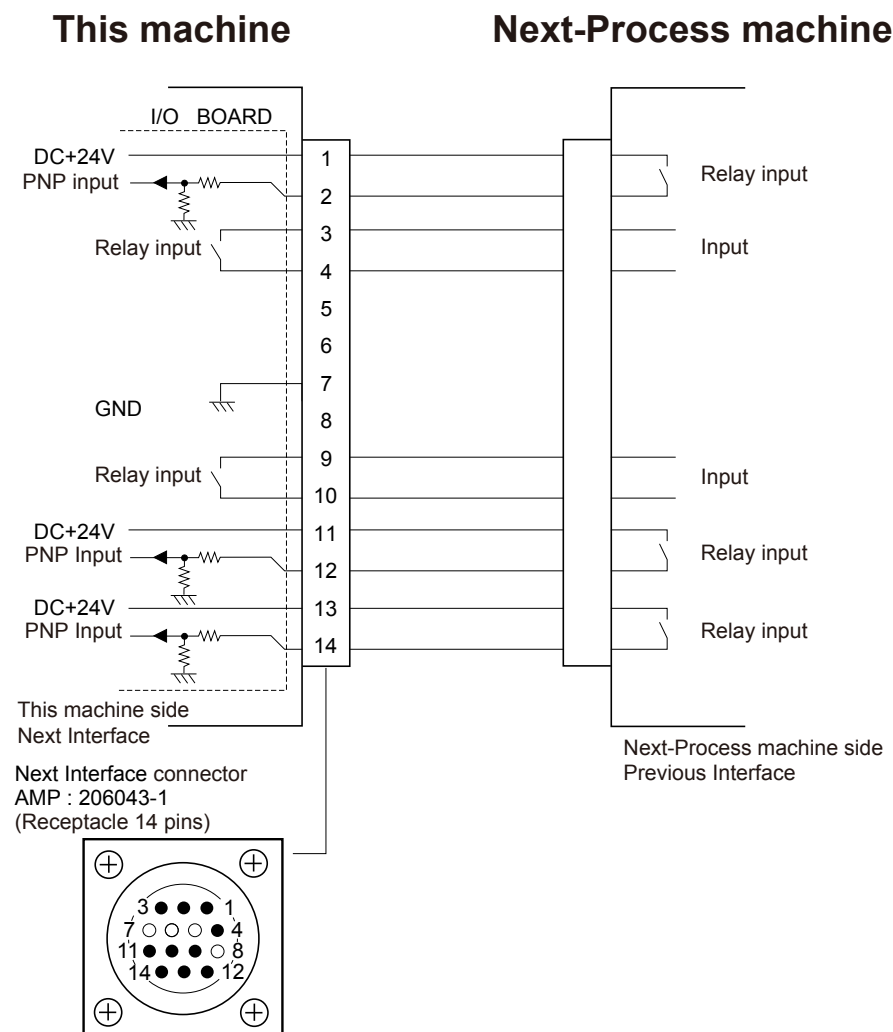

13. General Specifications

13.11.2 Inter-device signal specifications (Between this machine the previous-process machine)

* Previous Interface

Select the appropriate signal specifications from the table below in accordance with the operating conditions such as the machine combinations and signal cables, etc.

To be matched with the selection made in section 13.11.1 "Inter-device signal specifications" (between this machine and next-process machine: Next Interface).

* When linking this machine to an other-brand machine, the customer is responsible for obtaining the required information regarding that machine's functions, etc.

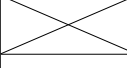
Selection								
Next Interface This machine's connector AMP: 206043-1 (14-pin receptacle)		GATE signal specs.		Advanced (extension) GATE signal specs.	Advanced (extension) GATE 2 signal specs.	SHEMA signal specs.		
		Yamaha machines up to and including the YV generation & other-brand machines		Yamaha machines beginning from the X generation (early X / Xg / YG / YS models)	Yamaha machines beginning from the YS generation *1 From November, 2009	SHEMA signal conformance machine		
Pin No.	Category		Signal Name		Signal Name		Signal Name	
1	Relay contact output	When the relay contact output is ON: Power ON / Closed	Gate Out (output)	Previous- process machine board unloading request signal output	Busy Out (output)	This machine "board loading in progress" status signal output	Same as left	
2	Relay contact output		Gate Out (output)		Busy Out (output)			
3	DC +24V		Not used		BA In (com)	Previous- process machine "board unloading enabled" status signal input	Same as left	
4	PNP input (ON judgment at +24V)		Not used		BA In (com)			
5	Incorrect connection prevention function application		Prescribed mating only (reception enabled)		Prescribed mating only (reception enabled)	Prescribed mating only (reception enabled)		
6		Key-plug filled	Prescribed mating only (blocked)		Prescribed mating only (blocked)	Prescribed mating only (blocked)		
7	Vacant		Vacant		Vacant		SHEMA specs.	
8	Vacant		Vacant		Vacant			
9	DC +24V		Not used		UR In (com)	Previous- process machine "AUTO operation in progress" status signal input		
10	PNP input (ON judgment at +24V)		Not used		UR In (com)			Same as left
11	Relay contact output	When the relay contact output is ON: Power ON / Closed	Not used		LR Out (output)	This-machine AUTO operation in progress signal output	Same as left	
12	Relay contact output		Not used		LR Out (output)			
13	Relay contact output	When the relay contact output is ON: Power ON / Closed	Not used		Not used		LE OUT (output)	"Board standby between machines" signal output to previous-process machine
14	Relay contact output		Not used		Not used		LE OUT (output)	

*1 The "Advanced GATE 2" specifications are supported by YS / YG generation machines which were shipped beginning from November, 2009. Linking earlier YS / YG generation machines to the line requires modifications to those machines (excluding YS24).

13. General Specifications

YSD (SESLR13700-19) v2.019

- [Gate Out] This is the "board unloading request" output signal which this machine sends as a "power ON" notification to the previous-process machine after this machine's preparations are completed.
- [Busy Out] This output signal informs the previous-process machine that a "board loading in progress" status exists at this machine.
- [BA In] This input signal informs this machine that a "board unloading enabled" status exists at the previous-process machine. The previous-process machine is a relay contact output (dry contact: no-voltage circuit).
- [UR In] This input signal informs this machine that AUTO operation is in progress at the previous-process machine. The previous-process machine is a relay contact output (dry contact: no-voltage circuit).
- [LR Out] This output signal informs the previous-process machine that AUTO operation is in progress at this machine.
- [LE Out] This output signal is used in systems with Advanced (extension) GATE 2 signal specifications, when the "inter-machine board transfer standby" function is enabled. This output signal informs the previous-process machine that a board transfer standby status exists between this machine and the previous-process machine. The inter-device cable has a yellow marking near the cable connector.

Inter-device signal specifications (Between this machine the previous-process machine)

*** PREVIOUS INTERFACE**

Previous-process machine

This machine

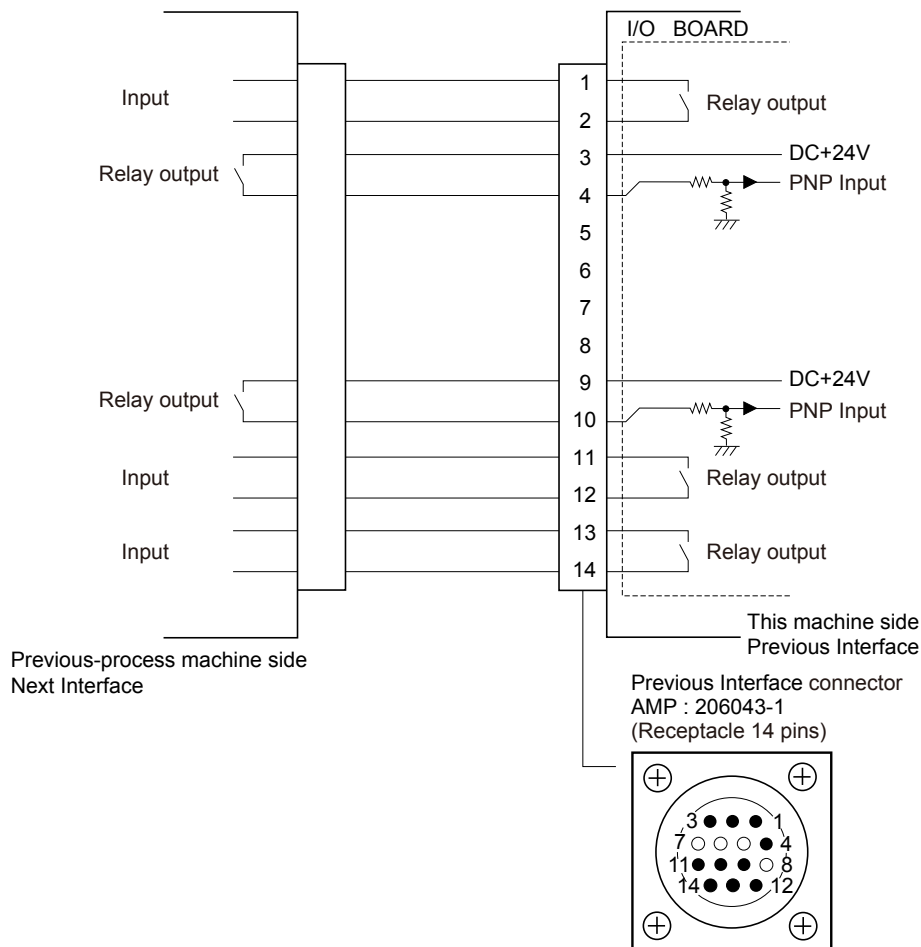

13.12 Syringe remaining level detection

Detects an impending syringe out-of-fluid condition, and activates an alarm, etc., to prevent dispensing faults. A sensor system is used for this purpose.

* The sensor threshold value must be adjusted for the fluid type being used.

Specifications

The following combinations are available.

If the type of syringe or piston is unknown, ask the glue maker.

Syringe volume	Syringe maker (Type)	Piston maker (Type)	Remaining stroke
30cc	Musashi Engineering (PSY-30E)	Musashi Engineering (FLP50-E)	5.7mm
	Iwashita Engineering (PS30S)	Iwashita Engineering (PP30S)	2mm
	Iwashita Engineering (PS30S)	Iwashita Engineering (PP30ND)	6mm
	Nordson EFD (7012134)	Nordson EFD (7012184)	2.7mm

* from empty level detectable position to stroke end position.

Caution

* Sensor may fail to detect empty level in the following cases.
Glue is left on the inside of syringe (above piston).
Syringe label is put on the detecting area.

14. Reference & Details

Item	Details				
Layout YSD	Board width	Max. board length	Conveyor IN port	Conveyor reference	Extended conveyor
	460mm	460mm 510mm	Right (R) Left (L)	Front (F) Rear (R)	Normal (N) Extended (E)

Layout list / 2 heads (standard)

Layout No.	Board width (W)	Max. board length (L)	Conveyor IN port	Conveyor reference	Extended conveyor
#001	460	460 (1 PCB's transport) 330 (3 PCB's transport)	Right	Front	Normal
#002		510 (1 PCB's transport)			
#004		460 (1 PCB's transport) 420 (3 PCB's transport)			
#005		510 (1 PCB's transport)			
#011		460 (1 PCB's transport) 330 (3 PCB's transport)	Left		Normal
#012		510 (1 PCB's transport)			
#014		460 (1 PCB's transport) 420 (3 PCB's transport)			
#015		510 (1 PCB's transport)			
#051		460 (1 PCB's transport) 330 (3 PCB's transport)	Right	Rear	Normal
#052		510 (1 PCB's transport)			
#054		460 (1 PCB's transport) 420 (3 PCB's transport)			
#055		510 (1 PCB's transport)			
#061		460 (1 PCB's transport) 330 (3 PCB's transport)	Left		Normal
#062		510 (1 PCB's transport)			
#064		460 (1 PCB's transport) 420 (3 PCB's transport)			
#065		510 (1 PCB's transport)			

Layout list / 3 heads (optional)

Layout No.	Board width (W)	Max. board length (L)	Conveyor IN port	Conveyor reference	Extended conveyor
#003	460	460 (1 PCB's transport) 330 (3 PCB's transport)	Right	Front	Normal
#006		460 (1 PCB's transport) 420 (3 PCB's transport)			
#013		460 (1 PCB's transport) 330 (3 PCB's transport)	Left		Normal
#016		460 (1 PCB's transport) 420 (3 PCB's transport)			
#053		460 (1 PCB's transport) 330 (3 PCB's transport)	Right	Rear	Normal
#056		460 (1 PCB's transport) 420 (3 PCB's transport)			
#063		460 (1 PCB's transport) 330 (3 PCB's transport)	Left		Normal
#066		460 (1 PCB's transport) 420 (3 PCB's transport)			

Item	Details
Head type	Dispensing head
<div data-bbox="197 306 711 1010" data-label="Image"> </div> <div data-bbox="197 1016 1264 1111" data-label="List-Group"> <ul style="list-style-type: none"> * Selectable as “2 heads” (standard) or “3 heads” (optional). * The number of FID cameras and their dispensing locations vary according to the system specifications. * The figure above shows just one example of a nozzle dispensing configuration. </div>	

14. Reference & Details

YSD (SESLR13700-19) v2.019

Nozzle for 2-point dispensing

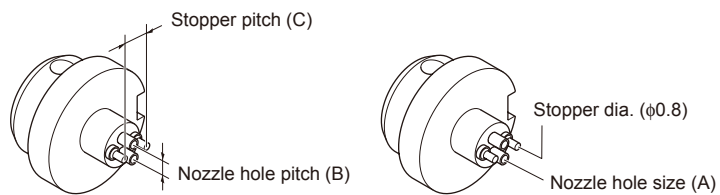

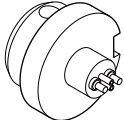
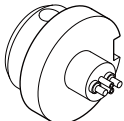
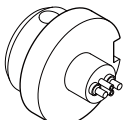
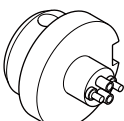
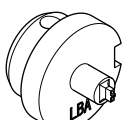
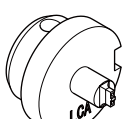
Item	Details					
	Nozzle type	Outer shape	Dimension			Compatible Components (mm)
A (φ)			B (mm)	C (mm)		
Nozzle for 2-point dispensing	Type 111		0.4	0.9	2.4	1608 & 2125 size
	Type 11A		0.4	0.8	2.4	1608 size
	Type 112		0.5	1.1	2.4	2012 size
	Type 113		0.9	1.8	3.2	SOP / QFP
	Type LBA		0.4	0.9	–	For dispensing glue to solder-printed boards. Applicable chip size is the same as Type 111.
	Type LCA		0.4	1.2	–	For dispensing glue to solder-printed boards. Applicable chip size is the same as Type 112.

Solvents used for nozzle cleaning

Since the nozzle stopper is made of steel, using water or a water-based solvent to clean the nozzle may corrode the stopper. As a general rule, use organic solvents such as anhydrous ethanol. For cleaning solvents suitable for the adhesive you use, please contact the adhesive manufacturer.

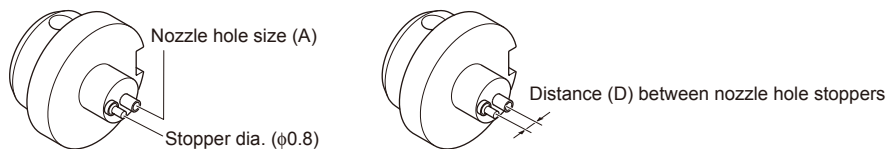

Nozzle for 1-point dispensing

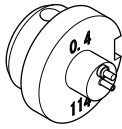
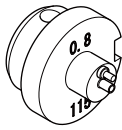
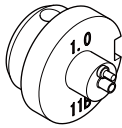
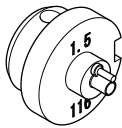
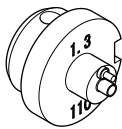
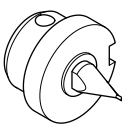
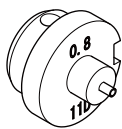
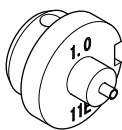
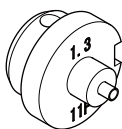
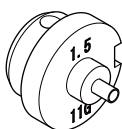

Item	Details				
	Nozzle type	Outer shape	Dimension		Compatible Components (mm)
A (φ)			D (mm)		
Nozzle for 1-point dispensing	Type 114		0.4	1.6	1608 size
	Type 115		0.8	1.6	SOP / QFP
	Type 11B		1.0	1.6	SOP / QFP
	Type 116		1.5	1.8	QFP / PLCC
	Type 11C		1.3	1.8	Large components
	Type 117 (Non-contact dispensing)		0.4	—	1608 size
	Type 11D (Non-contact dispensing)		0.8	—	SOP / QFP
	Type 11E (Non-contact dispensing)		1.0	—	SOP / QFP
	Type 11F (Non-contact dispensing)		1.3	—	Large components
	Type 11G (Non-contact dispensing)		1.5	—	QFP / PLCC





14. Reference & Details

YSD (SESLR13700-19) v2.019

Item	Details	
Dot station KLR-M9300-00X 	With / optional	Without / standard * Dot plate is a standard item. KLR-M9300-50X
Dot station roll paper KM4-M9330-01X	With / optional * Replenishment roll paper (50m)	Without / standard
Dispensing fluid discarding cup		
Fiducial camera	With / standard	
Laser unit  * Required for non-contact dispensing and drawing dispensing	With / optional	Without / standard
Conveyor IN port	Left / optional	Right / standard
Conveyor reference	Rear / optional	Front / standard
Conveyor specs.	With extension / optional ==> [E] (extended) * Max. board length for standby inside single machine: L420mm. If less than L420mm, a buffer is possible at the loading/unloading zones. * A longer board standby is possible with the "Machine-to-machine board standby function".	
	Without extension / standard ==> [N] (normal) * Max. board length for standby inside single machine: L330mm. If less than L330mm, a buffer is possible at the loading/unloading zones. * A longer board standby is possible with the "Machine-to-machine board standby function".	

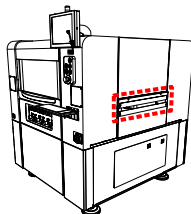

14. Reference & Details

YSD (SESLR13700-19) v2.019

Item	Details	
Operation panel  * LCD monitor, operation panel	Front side only + Without rear side safety cover	
Keyboard 	With / optional	Without / standard
Touch panel function 	With / standard	
Display language	English	Chinese
	Korean	Japanese
Display indicator lamp height KHY-M4899-XXX, Light 1 Assy	Top height : 2,300mm	Top height : 2,200mm
	Top height : 2,100mm	Top height : 2,000mm
	Top height : 1,900mm	Top height : 1,850mm / standard
Indicator lamp color pattern (indicator lamp + operation panel)	White / blue / green <For Europe / CE region>	Red / yellow / green <For Japan / Yamaha standard>
Operation manual language (handling manual + operation manual + maintenance manual)	English	Chinese
	Korean	Japanese
Outer cover color	Present / special-order * Requires a color sample and ample time for delivery.	
	Absent / standard	
Muzzle plate  * Restricts the opening surface area of the conveyor IN/OUT ports.	Extended conveyor safety part / optional KHY-M13K0-10X, Plate Muzzle Assy	
	Standard conveyor safety part / optional KHY-M13K0-00X, Plate Muzzle Assy	
	Without / standard	
CE compliance label 	Present / standard KHY-M6417-00X , Seal CE	
	Absent / used for special orders	

14. Reference & Details

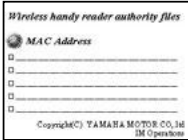
YSD (SESLR13700-19) v2.019

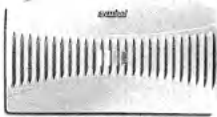
Item	Details	
Power supply voltage * 3-phase AC	416V	400V
	380V	240V
	220V	208V
	200V / Japan standard	
IT option Basic package (for V30 generation) * A server utility program [IT System] is required in order to use this function.	Present / IT option installed / wireless Handy Reader specs. (without barcode reader) <Function> Setup verify (moulder internal setup) * In a "without barcode reader (BCR)" configuration, the [Wireless Handy Reader] is required in order to perform the "setup verify (internal setup)" function.	
	Present / IT option installed / * 2 barcode readers (BCR) specs. <Function> Setup verify (moulder internal setup) <Installed 1> RS232C communication card <Installed 2> 1 barcode readers (RS232C)* * Barcode readers (BCR) are installed at both the front and rear of the machine.	
	Absent / standard	
Automatic setup change * Note that the prices are different for the 1st unit and subsequent connection units.	Present / IT option extension function * For 1st unit.	
	Present / IT option extension function * For 2nd and subsequent units.	
	Absent	
Wireless authentication code (For wireless Handy Reader) 	KHY-M4980-70X, Soft Wireless Handy Reader Assy * Required quantity is the same as the number of wireless Handy Readers (hardware) being used. * For overseas users, assign the code to the wireless Handy Reader upon delivery to the worksite.	
Wireless Handy Reader (Japan standard compliant)  * Hardware only	KHY-M55D4-XXX, Hard Wireless Handy Reader Selection * Because this model does not conform to overseas radio regulations, it cannot be exported.	
Wireless access point (Japan standard compliant) 	KGA-M55F4-00X, Access Point Assy * Because this model does not conform to overseas radio regulations, it cannot be exported.	
Provided LAN cable * For network communication	5m	KGA-M55G0-00X, LAN cable 5m
	10m	KGA-M55G0-10X, LAN cable 10m
	30m	KGA-M55G0-40X, LAN cable 30m

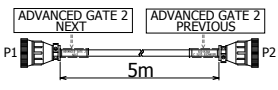
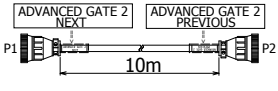
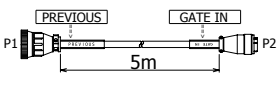
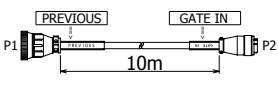
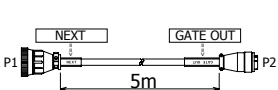
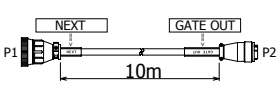
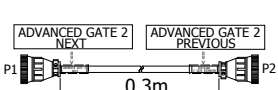
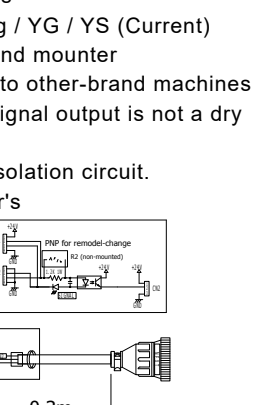

14. Reference & Details

YSD (SESLR13700-19) v2.019

Item	Details		
Inter-machine signal line	Previous-process achine ==> X / Xg / YG / YS (Current) Next-process machine ==> X / Xg / YG / YS (Current) Length: 5m		KV7-M66V1-02X, Harness advanced gate 2 L=5000
	* Supports the "Inter-machine board transfer standby" function when machines are linked.		
	Previous-process machine ==> X / Xg / YG / YS (Current) Next-process machine ==> X / Xg / YG / YS (Current) Length: 10m		KV7-M66V1-12X, Harness advanced gate 2 L=10000
	* Supports the "Inter-machine board transfer standby" function when machines are linked.		
	Previous-process machine ==> YV and earlier (old) Next-process machine ==> X / Xg / YG / YS (Current) Length: 5m		KV7-M66V3-01X, Harness advanced gate
	Previous-process machine ==> YV and earlier (old) Next-process machine ==> X / Xg / YG / YS (Current) Length: 10m		KV7-M66V3-11X, Harness advanced gate
	Previous-process machine ==> X / Xg / YG / YS (Current) Downstream:Next-process machine ==> YV and earlier (old) Length: 5m		KV7-M66V2-01X, Harness advanced gate
	Previous-process machine ==> X / Xg / YG / YS (Current) Downstream: Next-process machine ==> YV and earlier (old) Length: 10m		KV7-M66V2-11X, Harness advanced gate
	Between previous-process & next-process YG100 machines ==> YG100 / YG88, YS100 / YS88 etc. Length: 0.3m		KGS-M66V1-01X, Harness advanced gate 2 L=300
* Supports the "Inter-machine board transfer standby" function when machines are linked.			
* For other-brand machine connections Previous-process machine ==> X / Xg / YG / YS (Current) Next-process machine ==> Other-brand mounter * This harness is used for connecting to other-brand machines (mounter) where the board request signal output is not a dry contact (relay contact output) type. * Includes a photo-coupler electrical isolation circuit. * The connection work is the customer's responsibility.		KV7-M66V7-00X, Harness option gate-in CE	

14. Reference & Details

YSD (SESLR13700-19) v2.019

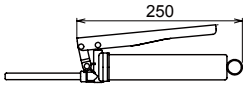
Item	Details	
Air supply cleaner (Product name : Sun drain)		K98-M3900-00X, Sun drain
Replacement filter (For air supply cleaner)	Rolled paper type filter element	K98-M3905-00X, Filter Spare
Standard tools		KV7-M3810-01X, Tool standard "K48-M3811-00X, Tool box" *1 "K48-M3821-00X, Hexagon wrench set" *1 "K48-M3831-00X, Driver 1 (D-2)" *1 "K48-M3832-00X, Driver 2" *1 "KV7-M3831-00X, Driver" *1 "KG2-M3861-00X, Vernier calipers" *1 "K48-M3841-00X, Spanner 1 (TS-01)" *1
Grease gun (injector)		KHW-M3852-A0X, Grease Gun Set

14. Reference & Details

YSD (SESLR13700-19) v2.019

Item	Details
IT option basic package * To operate this package, IT-system is needed.	Provided. (Option) / Without barcode reader
	Function 1: Setup verify * To operate the setup verify, wireless handy reader is needed.
	Provided. (Option) / With barcode reader
Automatic setup change-over	Function 1: Setup verify * Barcode reader is assembled into the machine.
	None (Standard)
	Provided. (Option) * IT option basic package is needed. * When switching the setup by reading 2D code on the board, the customer must prepare the reader. Additional COM port option for reader connection is required on the unit.
ELS automatic setup change-over	None (Standard)
	Provided. (Option) * It is recommended to use the IT option basic package together.
Material time limit management	None (Standard)
	Provided. (Option) * IT option basic package and wireless handy reader are needed.
	None (Standard)

14. Reference & Details

YSD (SESLR13700-19) v2.019

Yamaha SMT line support software
Y.FacT

* Requires a separate personal computer, hub, LAN wiring, etc. For details, please contact your distributor.



Item	Details
<p>P-Tool / programming tool (with license protection key) ⇒ Board data creation package & production startup preparation (CAD / CAM support)</p> <p>* Function package of the Y.FacT support software. * "YVi-OS" is required for editing the checking device data.</p> <p>K88-M4920-B0X, Software Y.FacT P-Tool Assy " K88-M4921-71X, FacT Tools instal I" *1 " K88-M4923-21X, Box for FD Assy " *1 " K88-M4926-40X, Registerd Hard-key P-Tool " *1</p>	<p>[Configuration elements]</p> <p>(1) Main unit functions ⇒ Board editor / board explorer / data base editor / feeder viewer</p> <p>(2) USB protection key (also referred to as a "hard key" or "dongle")</p> <p>(3) ASCII conversion function ⇒ CAD-BOM format (2 files) Compatible BOM : Bill of Materials (parts list)</p> <p>(4) Line data distribution function (multiple machine optimization)</p> <p>(5) Common setup optimizing function</p> <p>(6) Visual editor ⇒ simple desktop test mounting / automatic measurement of component dimensions</p>
<p>P-Tool ECO edition / programming tool (with license protection key)</p> <p>K88-M4920-T0X, Software Y.FacT P-ECO Assy " K88-M4921-70X, FacT Tools instal I" *1 " K88-M4923-21X, Box for FD Assy " *1 " K88-M4926-M0X, Registerd Hard-key P-ECO " *1</p>	<p>[Configuration elements]</p> <p>(1) Main unit functions ⇒ Board editor / board explorer / data base editor / feeder viewer</p> <p>(2) USB protection key (also referred to as a "hard key" or "dongle")</p> <p>(3) ASCII conversion function ⇒ CAD-BOM format (2 files) Compatible BOM : Bill of Materials (parts list)</p> <p>* It is not possible to use both Manual Teaching and Pioneer Option Tools in the same system.</p>
<p>Manual teaching / P-Tool option (Visual editor function extension)</p>	<p>[Function]</p> <p>Shortens initial data creation time and improves quality. Component image pasting (shape drawing) verify / angle correction / coordinate correction (* POT2 function import selection)</p>

Item	Details
M-Tool / monitoring tool (with license protection key) ⇒ Line management package & Line remote monitoring (general-purpose LAN support)	[Configuration elements] (1) Main unit functions ⇒ Board editor / board explorer / data base editor / feeder viewer / Single machine optimizing (2) USB protection key (also referred to as a "hard key" or "dongle") (3) Line control function (4) Data communication (transmission / reception)
* Function package of the Y.FacT support software.	
K88-M4920-C0X, Software Y.FacT M-Tool Assy " K88-M4921-71X, FacT Tools install " *1 " K88-M4926-50X, Registered Hard-key M-Tool " *1	
IT-System / server utility program (with license protection key)	* For building a LAN system in a machine where S-Tool or IT option is installed. * One of these programs is required for each data management block (floor units, line units, etc.). [Configuration elements] (1) Server system building software (2) USB protect key (also referred to as a hard key or dongle) (3) Communication utility for each client personal computer other than the S-Tool personal computer
* Prerequisite item for S-Tool / IT option. * For installing in the server personal computer.	
K88-M4920-V0X, Software IT-System Assy " K88-M4921-90X, IT-System Installation Assy " *1 " K88-M4923-21X, Box for FD Assy " *1 " K88-M4926-B0X, Registered Hard-key System " *1	
Dashboard (Live / Analytics) / Monitoring Tool (with USB hardware key)	[Configuration elements] (1) Basic software ① Live Production Dashboard . . . Floor Monitor / Line Monitor ② Production Analytics Dashboard . . . OEE analysis / Productivity analysis / Parts Pickup Analysis ③ Dashboard manager (2) USB protection key (also referred to as a hard key or dongle)
* For installing in the server personal computer. * The machine requires a machine monitor (Op023) * A Tableau license is required to use Production Analytics Dashboard * IProDB / All Image Tracer / Board ID operation is required to use Process correlation	
K88-M49T3-000 DASHBOARD PC · K88-M49T4-A00 DASHBOARD PC INSTALL · K88-M49T6-000 HK,DASHBOARD PC · K88-M4923-210 BOX FOR FD ASSY	

14. Reference & Details

YSD (SESLR13700-19) v2.019

Item	Details
Version upgrade P-Tool (No license protection key)	K88-M4920-F0X , Software Y.FacT Version-Up * Only functions for which the customer possesses a license key are activated.
Version upgrade M-Tool (No license protection key)	K88-M4920-F0X , Software Y.FacT Version-Up * Only functions for which the customer possesses a license key are activated. * Installation CD-R only K88-M4921-71X, FacT Tools instal
Version upgrade IT-System (No license protection key)	K88-M4920-P0X , Software IT-System Version-Up * Installation CD-R only K88-M4921-90X, IT-System Installation Assy

14. Reference & Details

YSD (SESLR13700-19) v2.019

* Installed and operated in the same personal computer where P-Tool is installed.
Production startup support CAM system.

POT2
/ P-Tool external support system

(PFA brand)



[Basic functions]
Component & mark & block
image automatic teaching /
Desktop test mounting /
automatic measurement of
component dimensions /
automatic polarity check, etc.

Item

Item	Gerber image tool	Scanner accuracy correction kit	Automatic teaching & polarity check	PLUS kit	Standard CAM Converter	Mount Variation Importer	Glass gauge	Scanner Stand
Gerber image tool Gerber image Conversion software KHN-M49D0-00X, POT2 GERBER ASSY	○							
Scanner accuracy correction kit Scanner accuracy correction software Accuracy correction tool (Glass gauge, Scanner Stand) KHN-M49D0-10X, POT2 SCANNER ASSY		○					○	○
Automatic teaching & polarity check Automatic teaching & polarity check function KHN-M49D0-20X, POT2 AUTO-TCH ASSY			○					
PLUS kit General-purpose software Fluorescent sheet KHN-M49D0-30X, POT2 PLUS-KIT ASSY				○				
Standard CAM Converter Standard CAM Converter Software KHN-M49D0-40X, POT2 STD-CAM ASSY					○			
Mount Variation Importer Mount Variation Importer function KHN-M49D0-90X, POT2 BOMS ASSY						○		

Package

Item	Gerber image tool	Scanner accuracy correction kit	Automatic teaching & polarity check	PLUS kit	Standard CAM Converter	Mount Variation Importer	Glass gauge	Scanner Stand
Gerber set KHN-M49D0-50X, POT2 GERBER-SET ASY	○		○	○				
Gerber set + Standard CAM Converter KHN-M49D0-A0X, POT2 G-SET S-CAM ASY	○		○	○	○			
Gerber set + Mount Variation Importer KHN-M49D0-D0X, POT2 G-SET BOMS ASY	○		○	○		○		
Gerber set + Standard CAM Converter + Mount Variation Importer KHN-M49D0-G0X, POT2 G-SET SC BM ASY	○		○	○	○	○		
Scanner set KHN-M49D0-60X, POT2 SCANNER-SET ASY		○	○	○			○	○
Scanner set + Standard CAM Converter KHN-M49D0-B0X, POT2 S-SET S-CAM ASY		○	○	○	○		○	○
Scanner set + Mount Variation Importer KHN-M49D0-E0X, POT2 S-SET BOMS ASY		○	○	○		○	○	○
Scanner set + Standard CAM Converter + Mount Variation Importer KHN-M49D0-H0X, POT2 S-SET SC BM ASY		○	○	○	○	○	○	○
Scanner set (Exclude accuracy correction tool) KHN-M49D0-L0X, POT2 SS-GL ASY		○	○	○				
Scanner set (Exclude accuracy correction tool) + Standard CAM Converter KHN-M49D0-M0X, POT2 SS-GL SC ASY		○	○	○	○			
Scanner set (Exclude accuracy correction tool) + Mount Variation Importer KHN-M49D0-N0X, POT2 SS-GL BM ASY		○	○	○		○		
Scanner set (Exclude accuracy correction tool) + Standard CAM Converter + Mount Variation Importer KHN-M49D0-P0X, POT2 SS-GL SC BM ASY		○	○	○	○	○		
Full set KHN-M49D0-70X, POT2 FULL-SET ASY	○	○	○	○			○	○
Full set + Standard CAM Converter KHN-M49D0-C0X, POT2 F-SET S-CAM ASY	○	○	○	○	○		○	○
Full set + Mount Variation Importer KHN-M49D0-F0X, POT2 F-SET BOMS ASY	○	○	○	○		○	○	○
Full set + Standard CAM Converter + Mount Variation Importer KHN-M49D0-J0X, POT2 F-SET SC BM ASY	○	○	○	○	○	○	○	○
Full set (Exclude accuracy correction tool) KHN-M49D0-R0X, POT2 FS-GL ASY	○	○	○	○				
Full set (Exclude accuracy correction tool) + Standard CAM Converter KHN-M49D0-S0X, POT2 FS-GL SC ASY	○	○	○	○	○			
Full set (Exclude accuracy correction tool) + Mount Variation Importer KHN-M49D0-T0X, POT2 FS-GL BM ASY	○	○	○	○		○		
Full set (Exclude accuracy correction tool) + Standard CAM Converter + Mount Variation Importer KHN-M49D0-U0X, POT2 FS-GL SC BM ASY	○	○	○	○	○	○		
Standard CAM set KHN-M49D0-80X, POT2 STD-CAM-SET ASY			○	○	○			
Standard CAM set + Mount Variation Importer KHN-M49D0-K0X, POT2 SC-SET BOMS ASY			○	○	○	○		

Hardware

Item	Gerber image tool	Scanner accuracy correction kit	Automatic teaching & polarity check	PLUS kit	Standard CAM Converter	Mount Variation Importer	Glass gauge	Scanner Stand
Glass gauge KHN-M49D0-W0X, POT2 GLASS GAUGE ASY							○	

14. Reference & Details

YSD (SESLR13700-19) v2.019